

## Body Diameter = .875 in.

### Description:

- Non-precision wheel
- 45 lb. per bearing load rating
- Eight 5/32 in. dia. hardened steel balls
- Pressed steel outer shell

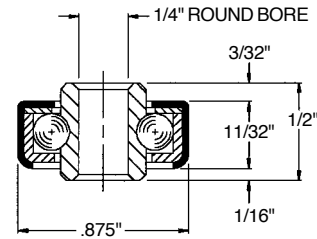

Part No. 102149

(578)

## Body Diameter = 1.375 in.

### Description:

- Precision ground bearing
- 75 lb. per bearing load rating
- Six 5/32 in. dia. hardened steel balls
- Molded nylon outer shell

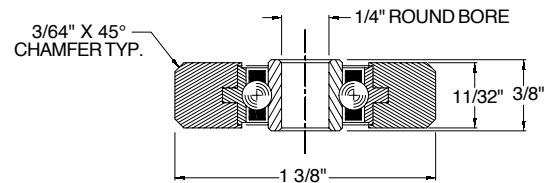

Part No. 113062

(SR2-EE52-22)

## Body Diameter = 1.938 in.

### Description:

- Non-precision wheel
- Seven 1/4 in. dia. hardened steel balls
- Pressed steel outer shell
- Rubber and neoprene boots available

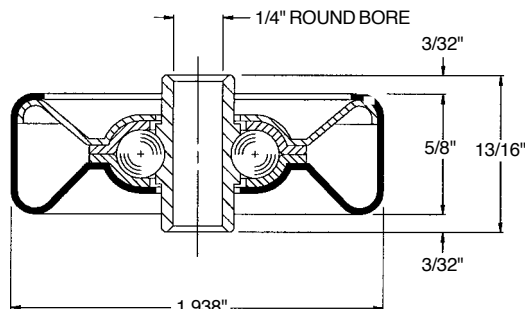

Part No. 102143

Galvanized Wheel  
50 lb. Per Wheel Load Capacity

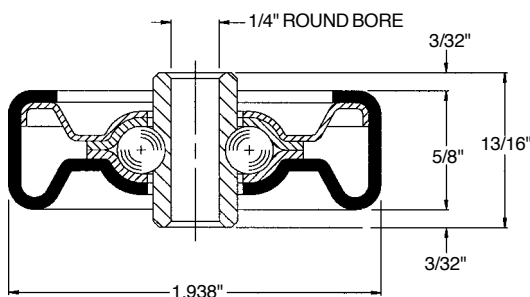

Part No. 102144

Aluminum Wheel  
55 lb. Per Wheel Load Capacity

### Description:

- Non-precision wheel
- 100 lb. per bearing load rating
- Eight 1/4 in. dia. hardened steel balls
- Pressed steel outer shell
- Rubber and neoprene boots available
- Skatewheels available with black or white plastic

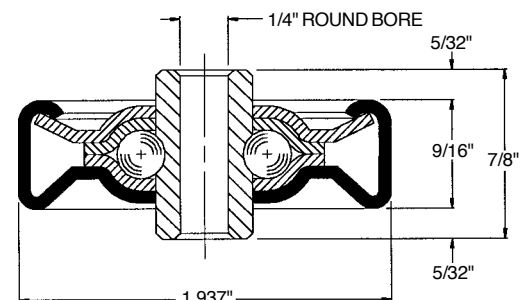

Part No. 102226

Galvanized Wheel

(53, A-12, 82)

## Body Diameter = 1.990 in.

### Description:

- Non-precision wheel
- 7/16-20 threaded stud with grease fitting
- 65 lb. per bearing load rating
- Seven 1/4 in. dia. hardened steel balls
- Pressed steel outer shell
- Rubber and neoprene boots available

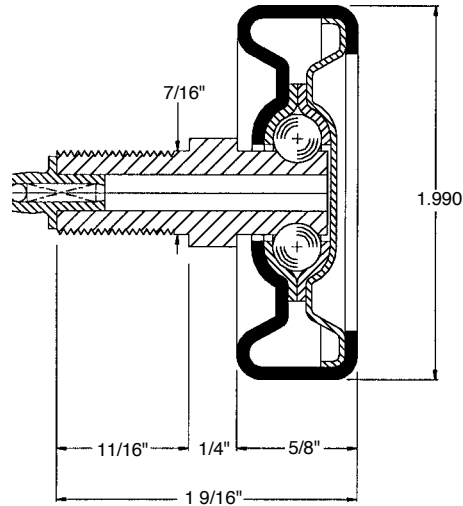

Part No. 102225

(CT-01)

## Body Diameter = 2.268 in.

### Description:

- Non-precision wheel
- 3/8-16 threaded stud
- 290 lb. per bearing load rating
- Eleven 3/8 in. dia. hardened steel balls
- Pressed steel outer shell

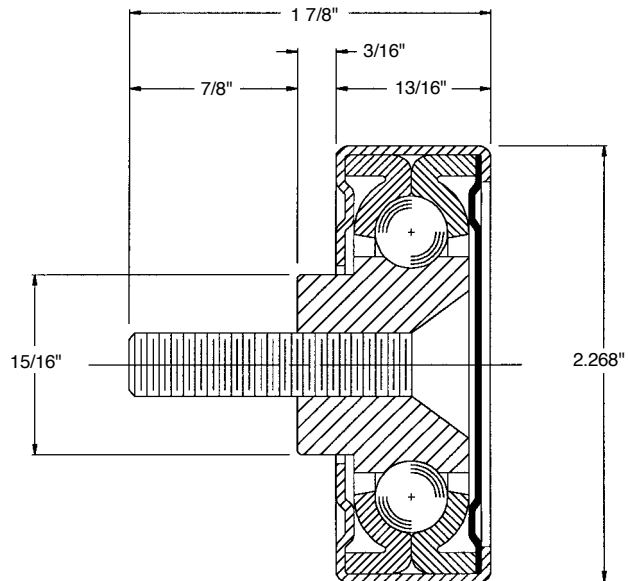

Part No. 102150

(64)